



# PHOENIX

## SPECIFICATIONS

### RADII

### BASIN MIXER

PRODUCT CODE: RA770 CHR  
 FINISH: CHROME  
 WELS: 5 STAR - 5 LT/MIN

#### INFORMATION:

MATERIAL: BRASS  
 TEMPERATURE RATING: MIN 1° - MAX 75°  
 PRESSURE RATING: MIN 150 kPa - MAX 500 kPa

#### CONSUMER UNIT:

SIZE: L 275MM x W 240MM x H 75MM  
 GROSS WEIGHT: 1.55 KG  
 BARCODE EAN-13: 9 320594 019 129



AVAILABLE IN:



CHROME

FOR MORE INFORMATION VISIT  
[www.phoenixtapware.com.au](http://www.phoenixtapware.com.au)

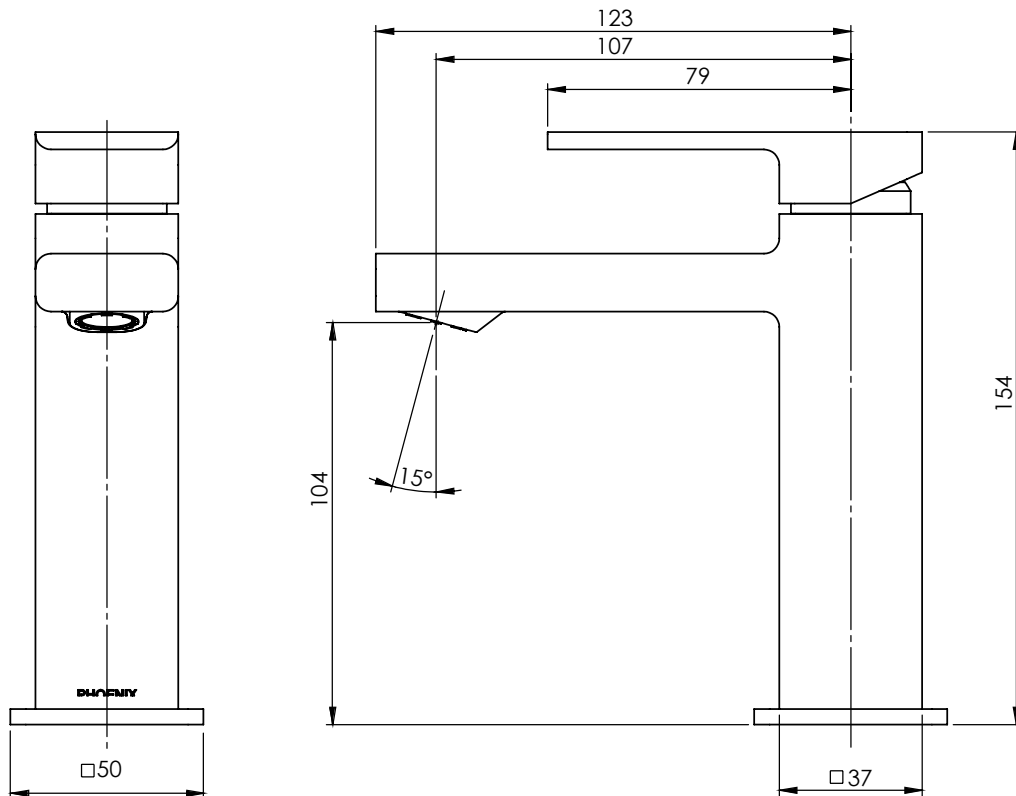

PLEASE [CLICK HERE TO VIEW FULL WARRANTY](#)

While we aim to ensure the specifications shown are correct at time of printing, Phoenix Tapware reserves the right to make modifications without prior notice. Always use the physical product measurements for mark-ups and roughing-in as the line drawing shown may differ from the actual product over time. All measurements are shown in millimetres.

Radii is a Registered Trademark of Phoenix Industries Pty. Ltd.

V300616

[www.phoenixtapware.com.au](http://www.phoenixtapware.com.au)  
03 9780 4200



# PHOENIX

## SPECIFICATIONS

### RADII

### BASIN MIXER

PRODUCT CODE:

RA770 CHR

FINISH:

CHROME

WELS:

5 STAR - 5 LT/MIN



#### PARTS LIST

1. BASIN MIXER BODY
2. CARTRIDGE SEAT
3. 25MM CARTRIDGE
4. MIXER DOME
5. MIXER HANDLE
6. MIXER DRESS PLATE
7. MIXER LOCKNUT 25MM
8. AERATOR
9. FLEXI HOSE
10. SCREW
11. O-RING 43X2.5MM
12. O-RING 21X2.5MM
13. O-RING 25X2.0MM
14. GRUB SCREW M4X5MM
15. GRUB SCR W M4X6MM
16. SCREW CAP
17. O-RING 22X2.7MM
18. PLASTIC MIXER LOCKNUT
19. GASKET RETAINER
20. LOCKNUT GAS

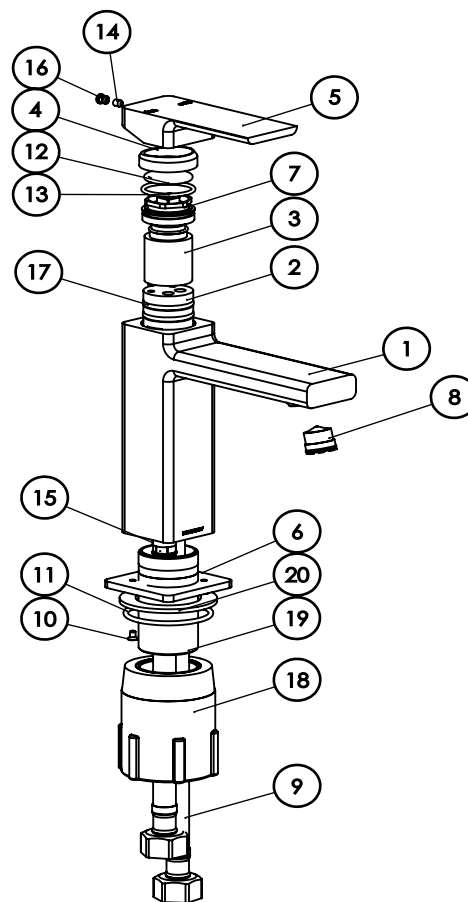

#### MAINTENANCE AND CARE:

- All surfaces should be cleaned with mild liquid detergent or soap and water.
- Do not use cream cleaners or citrus based cleaning products, as they are abrasive.
- Use of unsuitable cleaning agents may damage the surface. Any damage caused in this way will not be covered by warranty.

#### PACKAGING INCLUDES

- 1 x Basin mixer
- 1 x 450mm braided flexible cold hose
- 1 x 450mm braided flexible hot hose
- 1 x Installation kit
- 1 x Installation instructions
- 1 x Warranty card

PLEASE [CLICK HERE](#) TO VIEW FULL WARRANTY

While we aim to ensure the specifications shown are correct at time of printing, Phoenix Tapware reserves the right to make modifications without prior notice. Always use the physical product measurements for mark-ups and roughing-in as the line drawing shown may differ from the actual product over time. All measurements are shown in millimetres.

Radii is a Registered Trademark of Phoenix Industries Pty. Ltd.

V300616

[www.phoenixtapware.com.au](http://www.phoenixtapware.com.au)  
03 9780 4200